

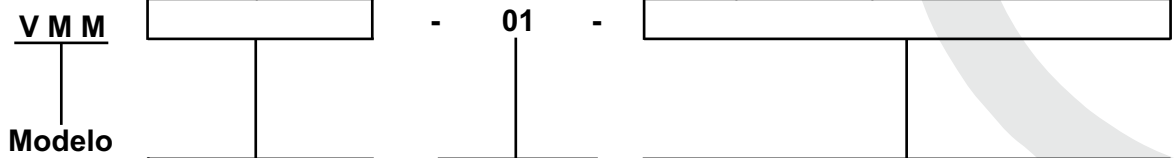

GHPC[®]

Tecnologia em Produtos Pneumáticos

Válvula Manual Miniatura Metálica 3/2vias ou 5/2vias - Série VMM



Vias	
3	3/2 vias
5	5/2 vias

Rosca	
01	1/8"

Modelos de Acionamento	
00M	Pino Miniatura
00	Pino
01M	Botão Seletor 2 Posições Miniatura
01	Botão Seletor 2 Posições
02	Rolete

Características Técnicas	
Fluído	Ar
Rosca	M5, 1/8"
Área de Secção (mm ²)	5.5
Pressão de trabalho (Bar)	0 ~ 8
Pressão de teste (Bar)	15
Temp. de trabalho (°C)	0 ~ 70
Lubrificação	Óleo de turbina classe 1 (ISO VG32)

Exemplo: **VMM3-01-02**
VMM3-01-00M
VMM5-01-01

Dimensional

VMM3-01-00M

3/2 Vias - Pino

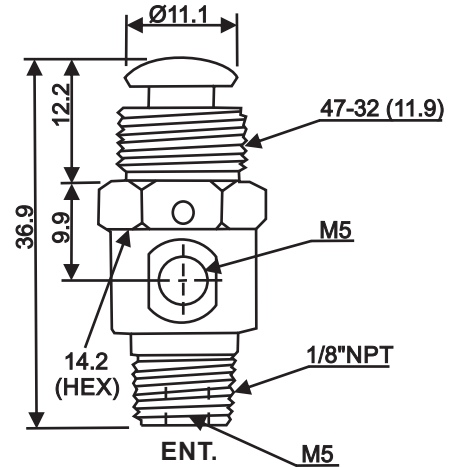

VMM3-01-01M

3/2 Vias - Botão Seletor 2 Posições

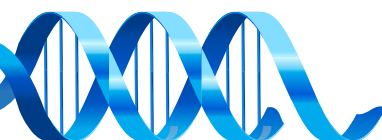
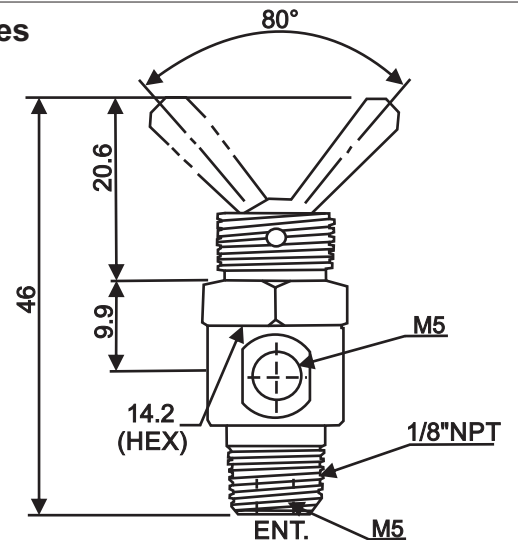

Válvula Manual Miniatura Metálica 3/2vias ou 5/2vias - Série VMM

VMM3-01-00

3/2 Vias - Pino

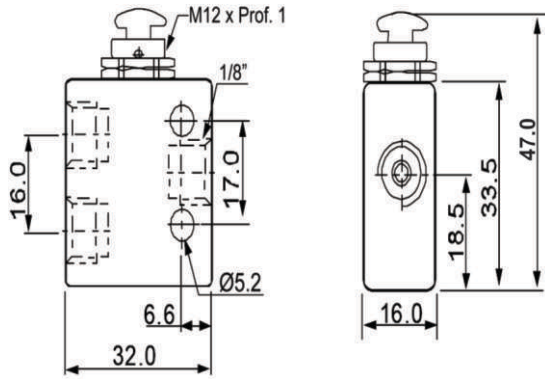

VMM5-01-00

5/2 Vias - Pino

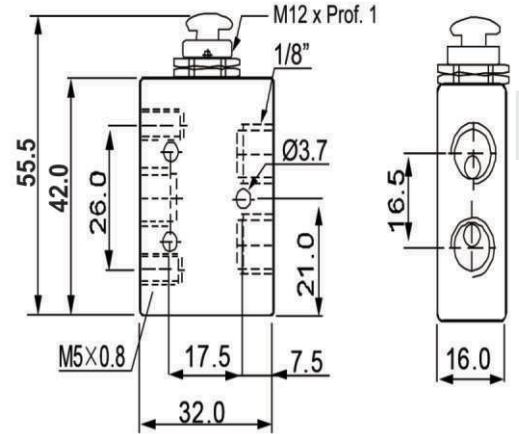

VMM3-01-01

3/2 Vias - Botão Seletor 2 Posições

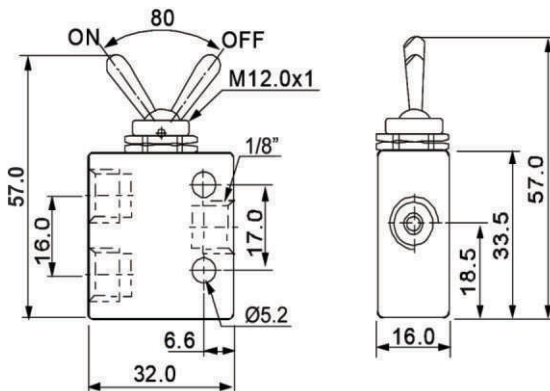

VMM5-01-01

5/2 Vias - Botão Seletor 2 Posições

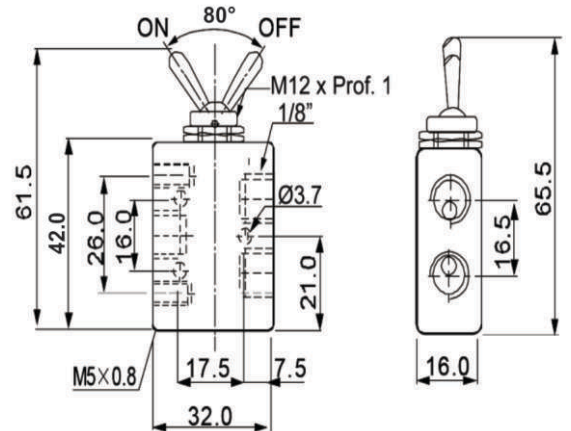

VMM3-01-02

3/2 Vias - Rolete

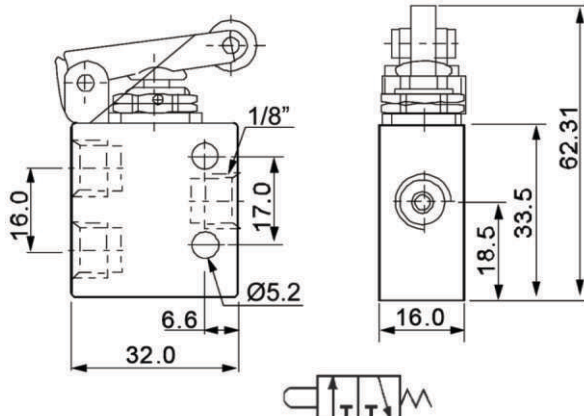

VMM5-01-02

5/2 Vias - Rolete

