

Motor Pneumático - MA-100

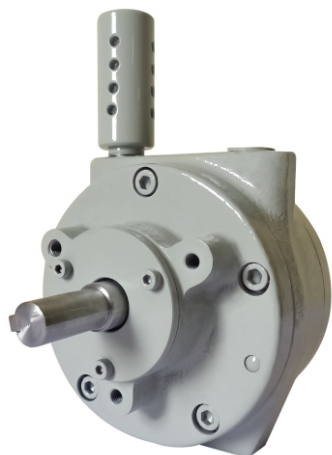

Simbologia

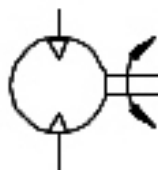

Características Técnicas	
Potência	1,0 HP
Torque (Máx.)	3,0 Nm
Rotação	300 à 3000 RPM
Reversível	Sim
Rosca Entr. e Saída de Ar	3/8" BSP
Pressão	3 à 7 Bar
Peso	5,0 Kg

Codificação

MA - 100

Curvas do Motor

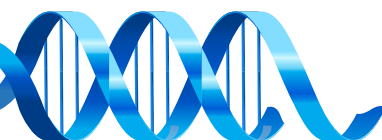
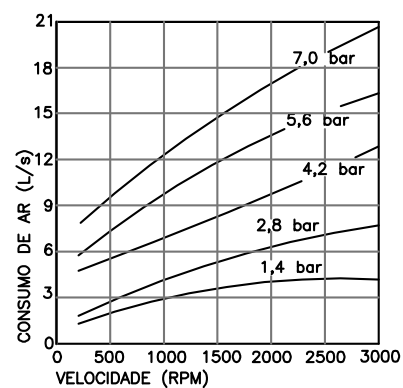
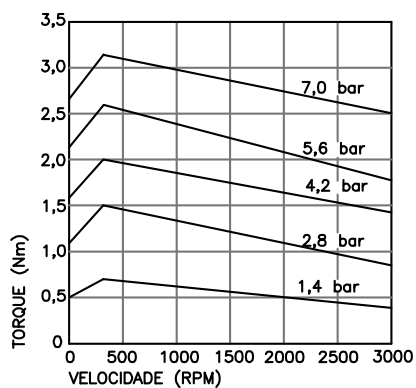
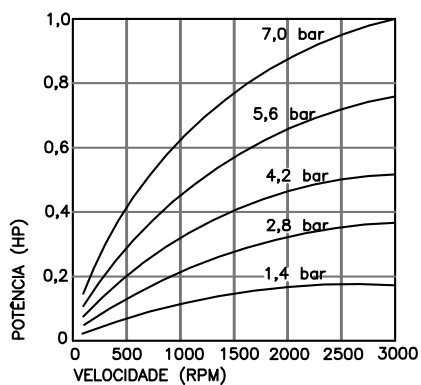



Codificação

FORMA CONSTRUTIVA COM FLANGE

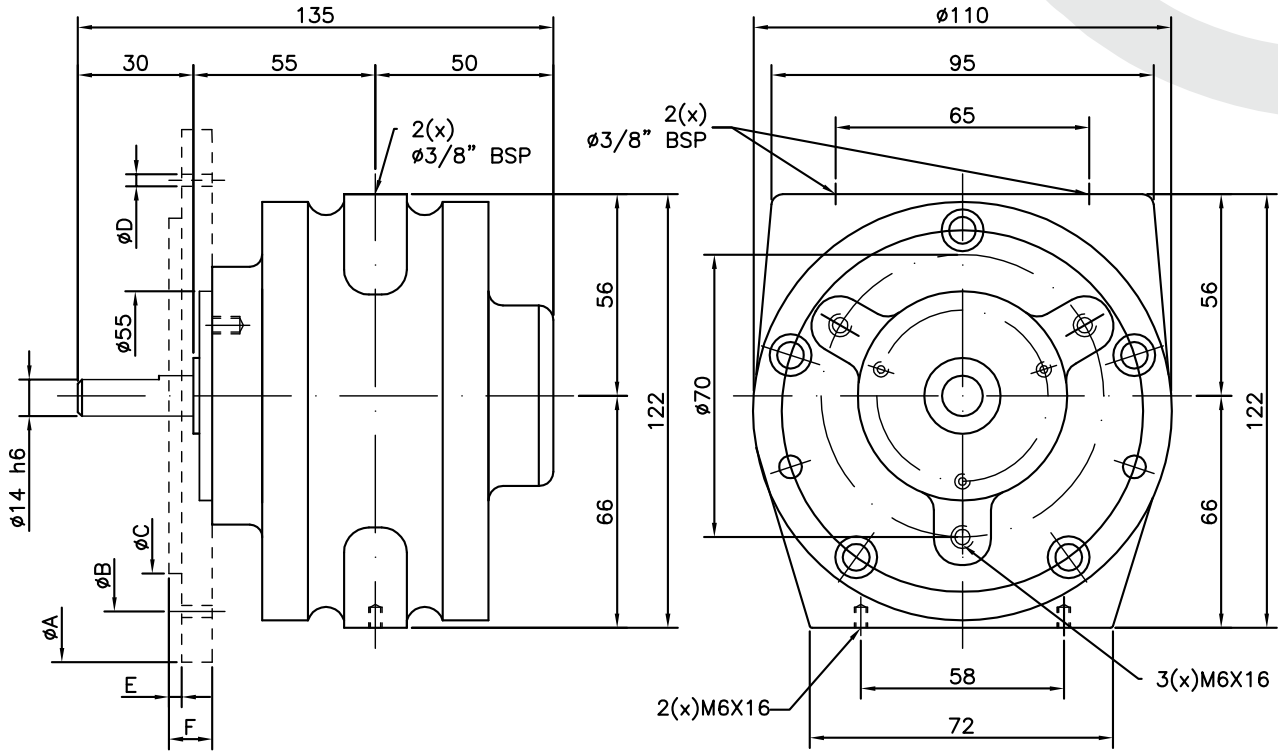

FORMA CONSTRUTIVA COM BASE

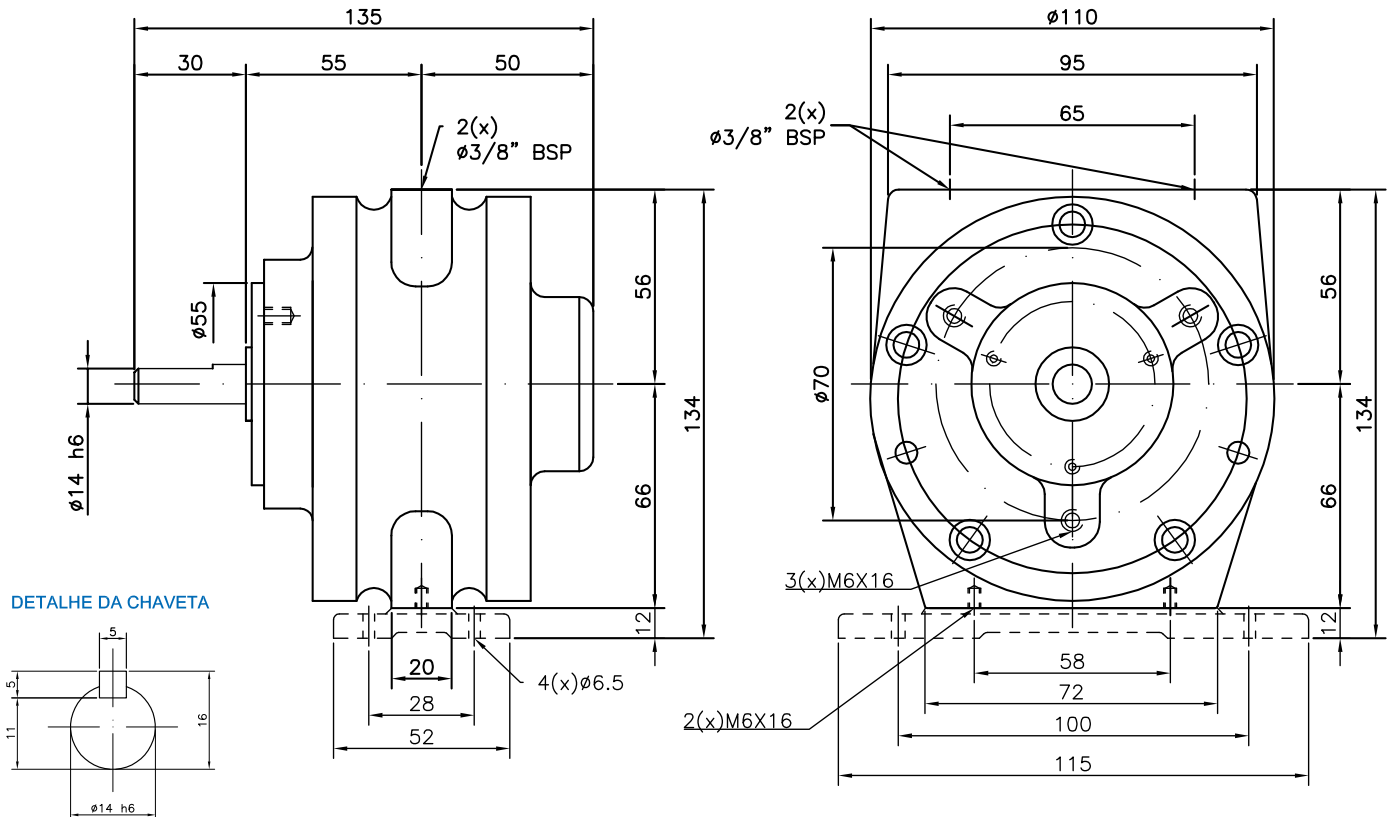

DETALHE DA CHAVETA

