

Motor Pneumático - MA-150

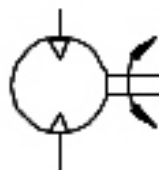

Simbologia



| Características Técnicas | |
|---------------------------|----------------|
| Potência | 1,5 HP |
| Torque (Máx.) | 6,0 Nm |
| Rotação | 300 à 3000 RPM |
| Reversível | Sim |
| Rosca Entr. e Saída de Ar | 3/8" BSP |
| Pressão | 3 à 7 Bar |
| Peso | 6,0 Kg |

Codificação

MA - 150

Curvas do Motor

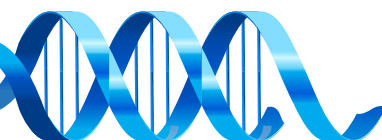
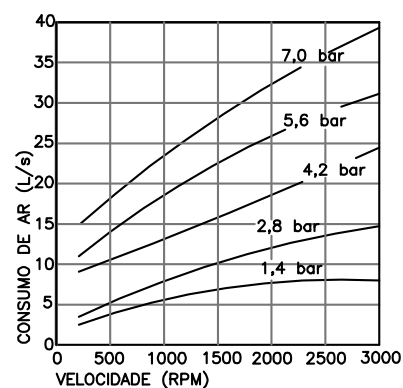
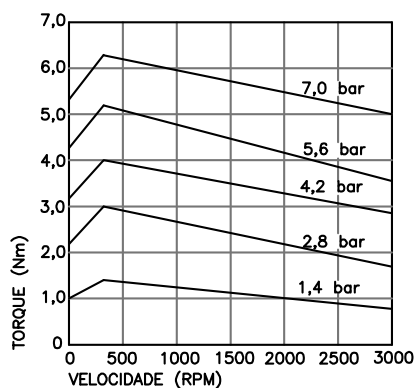
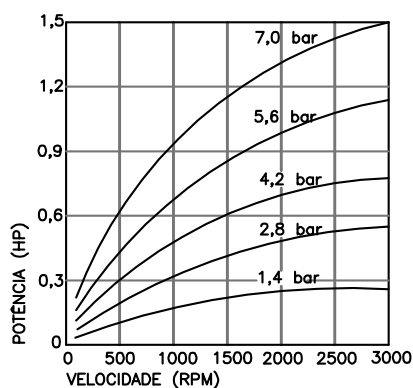



Codificação

FORMA CONSTRUTIVA COM FLANGE

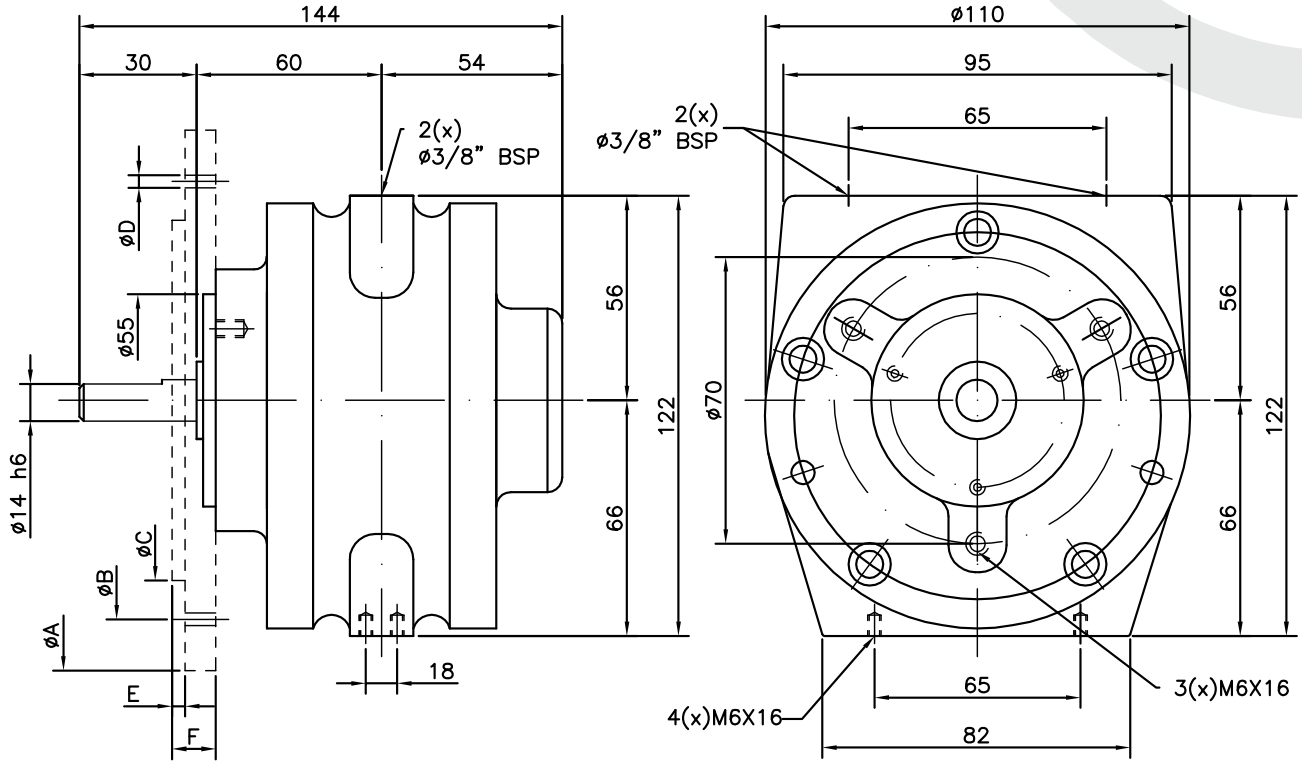

FORMA CONSTRUTIVA COM BASE

