

## Motor Pneumático - MA-200

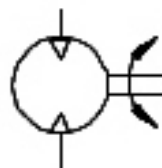

### Simbologia



Características Técnicas	
Potência	2,0 HP
Torque (Máx.)	8,0 Nm
Rotação	300 à 3000 RPM
Reversível	Sim
Rosca Entr. e Saída de Ar	1/2" NPT
Pressão	3 à 7 Bar
Peso	7,5 Kg

### Codificação

**MA - 200**

### Curvas do Motor

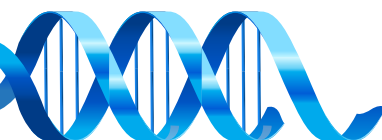
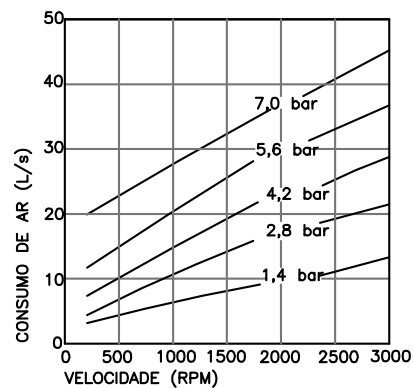
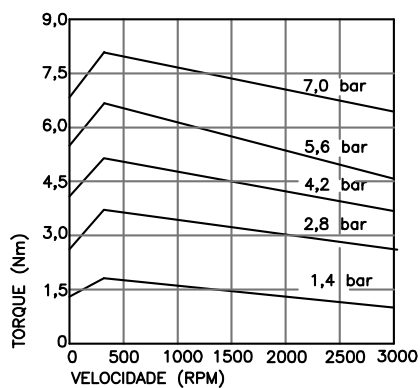
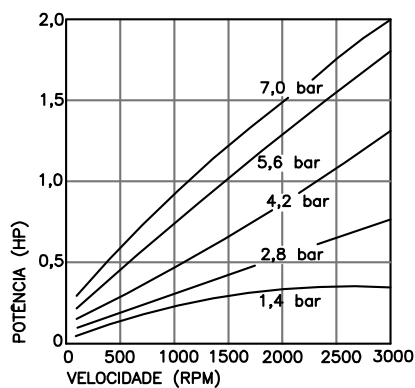

## Codificação

### FORMA CONSTRUTIVA COM FLANGE

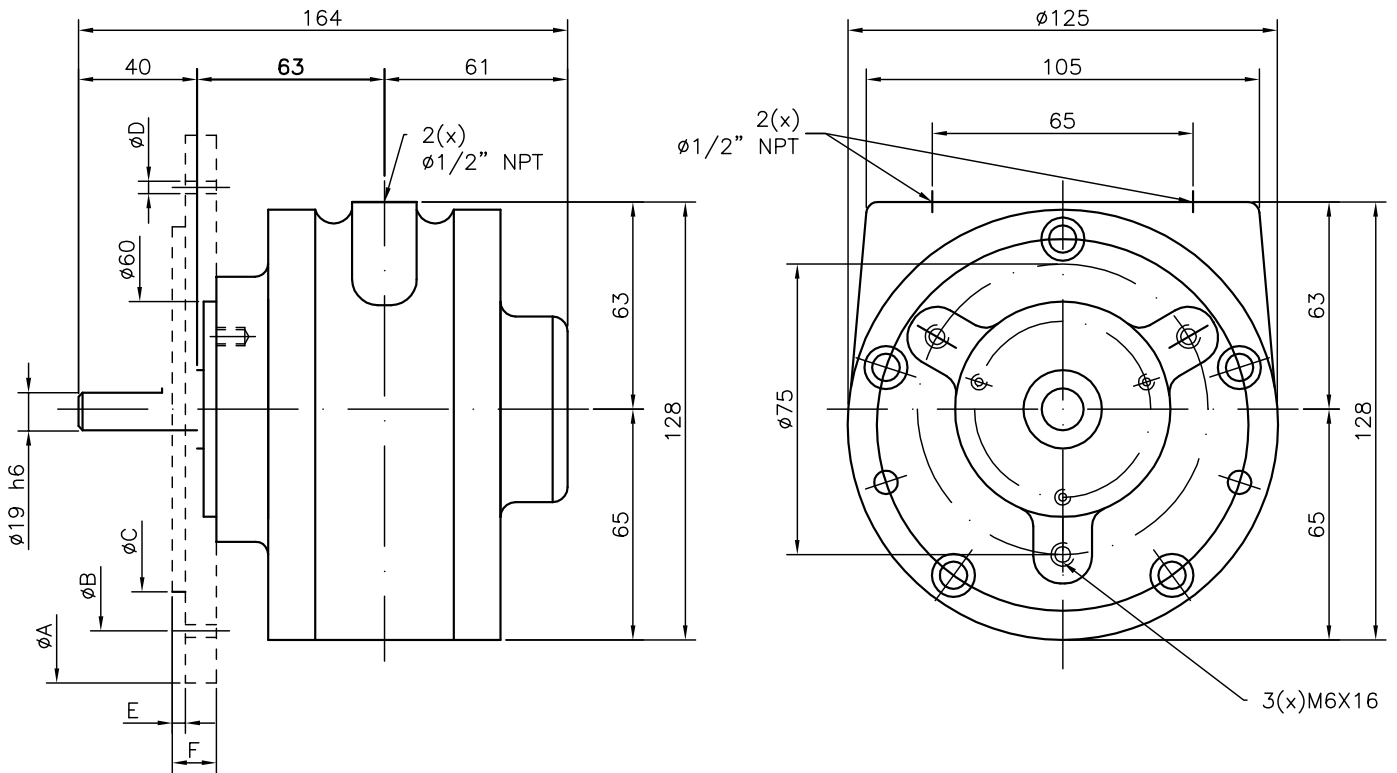

### DETALHE DA CHAVETA

