

Motor Pneumático - MA-600

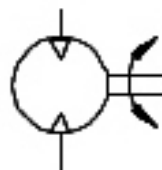

Simbologia



Características Técnicas	
Potência	6,0 HP
Torque (Máx.)	14,0 Nm
Rotação	250 à 2500 RPM
Reversível	Sim
Rosca Entr. e Saída de Ar	1" NPT
Pressão	3 à 7 Bar
Peso	12,0 Kg

Codificação

MA - 600

Curvas do Motor

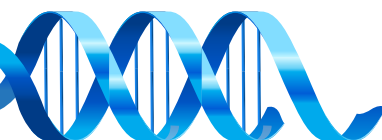
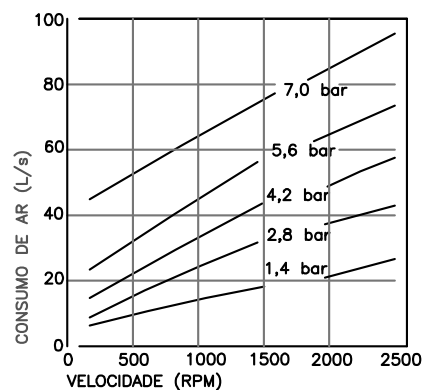
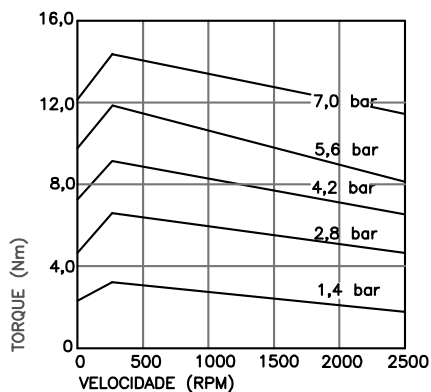
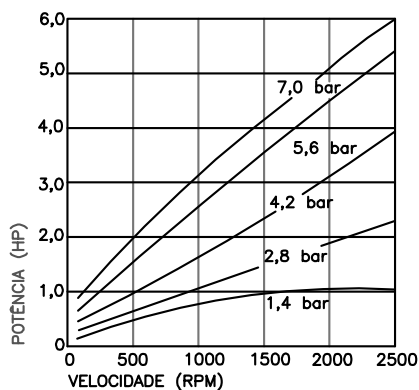

Codificação

FORMA CONSTRUTIVA COM FLANGE

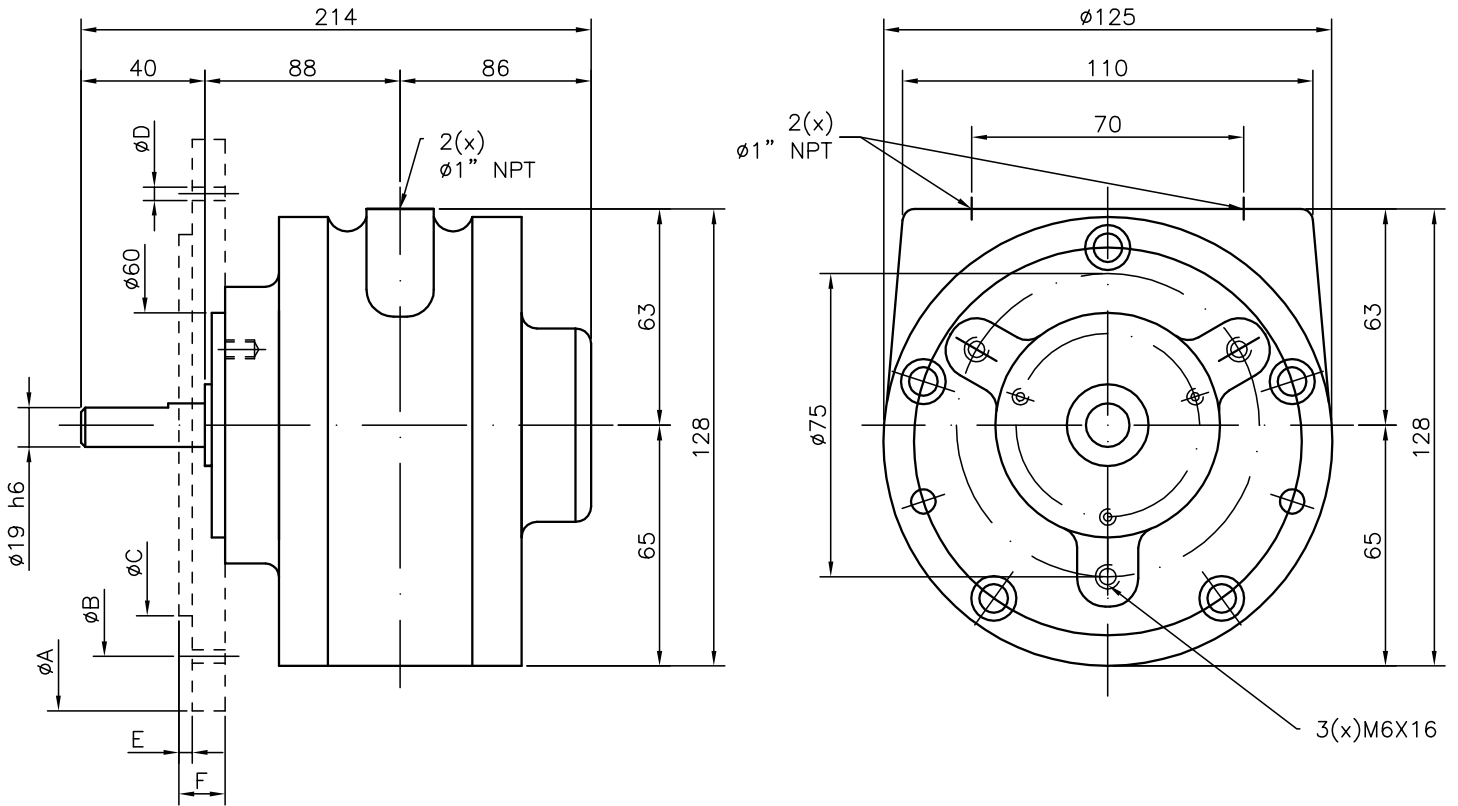

DETALHE DA CHAVETA

