

# Catálogo Técnico

## Filtro Regulador

**Série FR**



## Vantagens

- Robustez
- Alta precisão de trabalho
- Fácil substituição do elemento filtrante
- Com ou sem Dreno automático
- Com ou sem Manômetro Embutido



## Características Técnicas

Modelo	FR100	FR200	FR300	FR400	FR500
Rosca	M5 x 0.8	1/8", 1/4"	3/8"	1/2", 3/4"	1"
Máx. pressão de teste (Bar)	15				
Máx. pressão (Bar)	10				
Faixa de pressão (Bar)	0.5 ~ 7		0.5 ~ 8.5		
Rosca do Manômetro	5/16"	1/8"		1/4"	
Temperatura de trabalho (°C)	-5 ~ 60 (sem congelamento)				
Grau de Filtragem (µm)	5				
Vazão (l/min)	90	500	1700	3000	4000
Capacidade do dreno (cm³)	2.5	8	25	45	45
Material do copo	Policarbonato		Policarbonato + Proteção		

Simbologia:

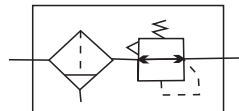

## Codificação

FR  
|  
Filtro e  
Regulador

Tamanho do Corpo
100
200
300
400
500

Rosca		Acessório	
M5	M5	---	Sem Manômetro
01	1/8"	M	Manômetro
02	1/4"	E	Manômetro Embutido
03	3/8"		
04	1/2"		
06	3/4"		
10	1"		

Dreno	
---	Manual
D	Automático N.A.

Exemplo:  
FR200-01M-D  
FR300-03-D  
FR400-04ME

Obs: Suporte e porca inclusos.

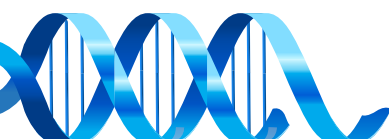

**Dimensional Padrão - FR100 à FR400**

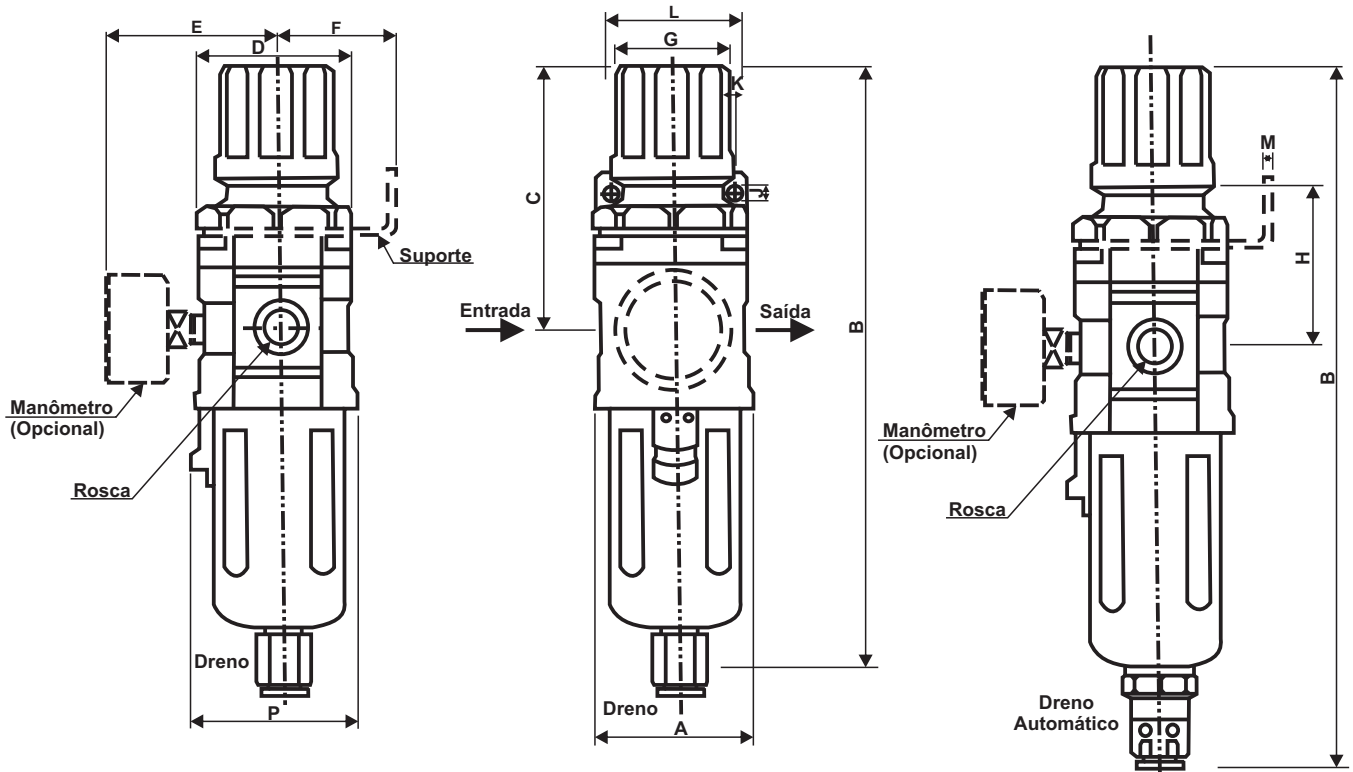

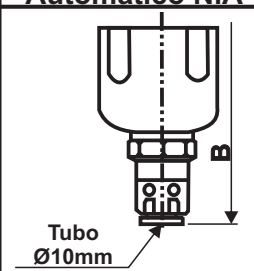
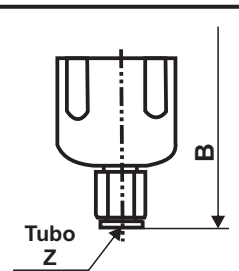
Opcionais	Dreno Automático N.A	Dreno Manual
	 <p>Tubo Ø10mm</p>	 <p>Tubo Z</p>

**Montagem em Painel**



Modelo	Rosca	A	B	C	D	E	Dimensões com suporte							N	P	B	Z
							F	G	H	J	K	L	M				
FR100	M5	25	109.5	50.5	25	26	25	28	30	4.5	6.5	40	2.0	20.5	28	130	6
FR200	1/8", 1/4"	40	164.5	78	40	56.8	30	34	44	5.4	15.4	55	2.3	33.5	40	187.5	6
FR300	3/8"	53	207.5	92.5	53	60.8	41	40	46	6.5	8.0	53	2.3	42.5	56	248.5	8
FR400	1/2", 3/4"	70	259	112	70	70.5	50	54	54	8.5	10.5	70	2.3	52.5	73	300	8

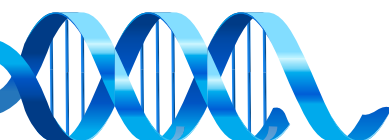

Dimensional Padrão - FR500

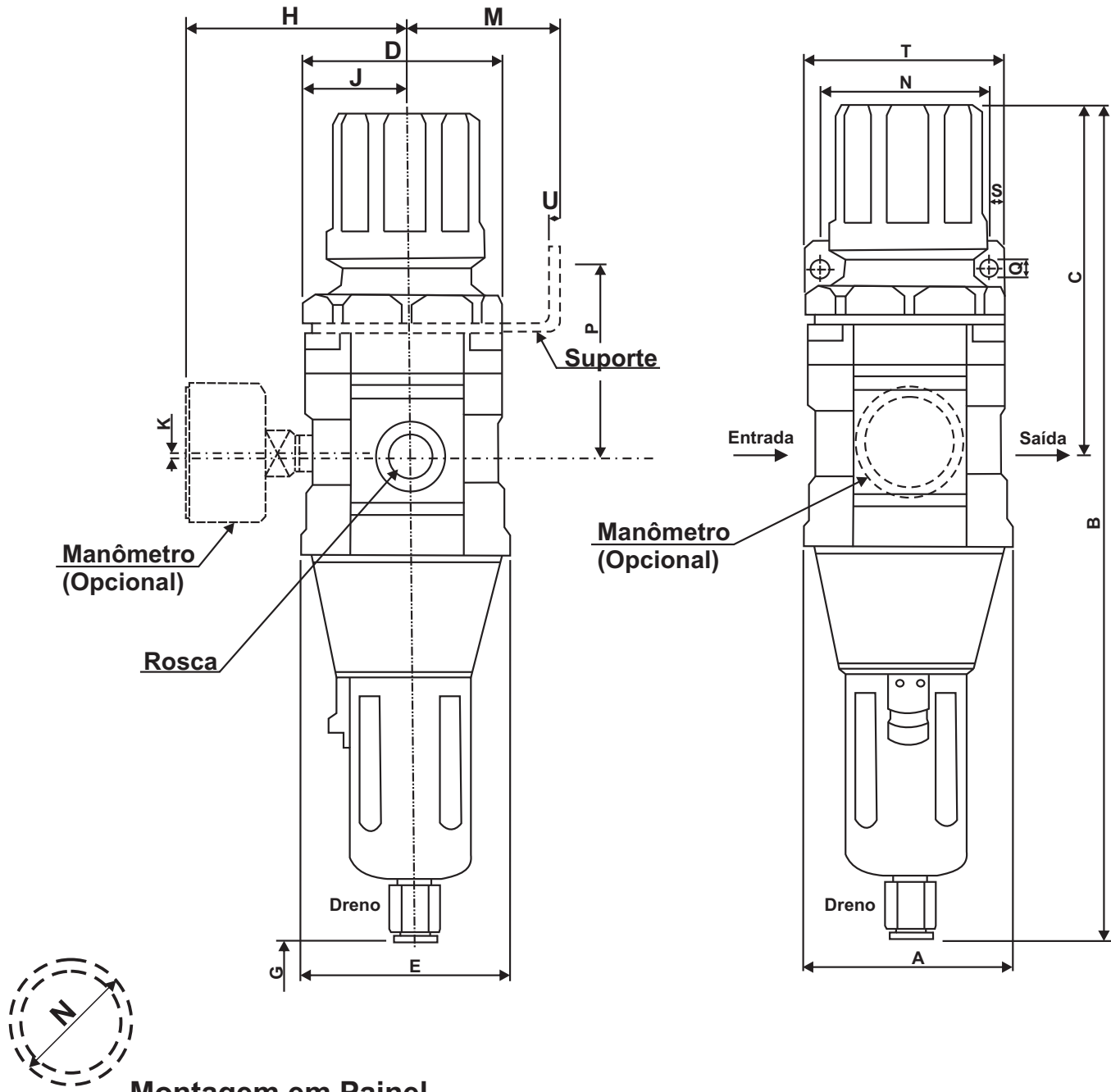

Montagem em Painel

Modelo	Rosca	Dimensionais							Com Manômetro			Com Suporte						Dreno Automático
		A	B	C	D	E	G	H	J	K	M	N	P	Q	S	T	U	B
FR500	1"	95	405	171	88	95	20	84	44.5	3.25	70	66	66	11	13	90	3.2	445

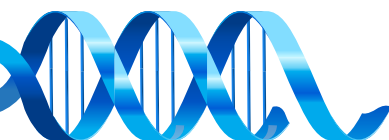



### Acessórios



Manômetro				
Código	Diâmetro	Escala (Kgf/cm <sup>2</sup> x PSI)	Rosca	Posição da Rosca
M41-10-01	41mm (1.5")	0 ~ 10	1/8"	Horizontal
M41-10-02	41mm (1.5")	0 ~ 10	1/4"	Horizontal



Elemento Filtrante - 5µm	
Modelo	Código
FRL100	EL-100
FRL200	EL-200
FRL300	EL-300
FRL400	EL-400
FRL500	EL-500



Copo com Dreno Manual para Filtro	
Modelo	Código
FRL100	CF-100
FRL200	CF-200
FRL300	CF-300
FRL400	CF-400
FRL500	CF-500



Copo com Dreno Automático para Filtro	
Modelo	Código
FRL100	CF-100D
FRL200	CF-200D
FRL300	CF-300D
FRL400	CF-400D
FRL500	CF-500D



Elemento de Fixação		
Modelo	Suporte	Porca
FR100	SR-100	P-100
FR200	SR-200	P-200
FR300	SR-300	P-300
FR400	SR-400	P-400
FR500	SR-500	P-500

### Acessórios para Montagem Modular

Derivação com 1 Saída  
**Série SH**

-Sistema Modular



Código	Rosca
SH-200	1/8"
SH-300	1/4"
SH-400	3/8"

Derivação com 4 Saídas  
**Série SZ**

-Sistema Modular



Código	Rosca
SZ-200	1/4"
SZ-300	3/8"
SZ-400	1/2"

Espaçador de União  
**Série SU**

-Sistema Modular



Código	Rosca
SU-200	1/8"/1/4"
SU-300	3/8"
SU-400	1/2"/3/4"
SU-500	1"

Espaçador de União com Suporte  
**Série ST**

-Sistema Modular

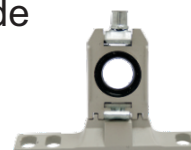

Código	Rosca
ST-200	1/8"/1/4"
ST-300	3/8"
ST-400	1/2"/3/4"
ST-500	1"

Válvula 3/2vias de Acionamento Manual com Trava de Segurança.  
**Série VS**

-Sistema Modular.  
-Com Entrada para Cadeado.  
-Em conformidade com a **NR12**

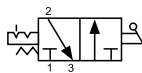

Código	Rosca	Vazão NI/min
VS200-02	1/4"	600
VS300-03	3/8"	1700
VS400-04	1/2"	3500
VS400-06	3/4"	4000
VS500-10	1"	6000

\*Condição de Alimentação a 7Bar.

\*\*Pressão Máxima de Trabalho 10Bar.

